

### Macho Motorized Directional Point Winch

**Macho PH X Y Z E**

- X:** Hoisting load in kg  
300 and 500
- Y:** Drum  
A size: 6mm grooves  
B size: 8mm grooves
- Z:** Lift lines : 1
- E:** export version

**Macho PH300A1E** Hoisting load 300kg

**Macho PH500B1E** Hoisting load 500kg



### Macho Directional Point Winch

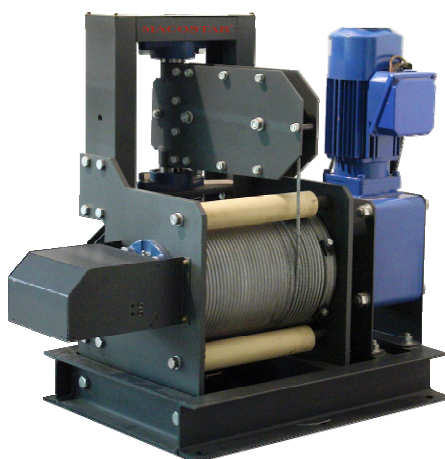

### Macho Directional Point Winch Outside Dimension Drawing

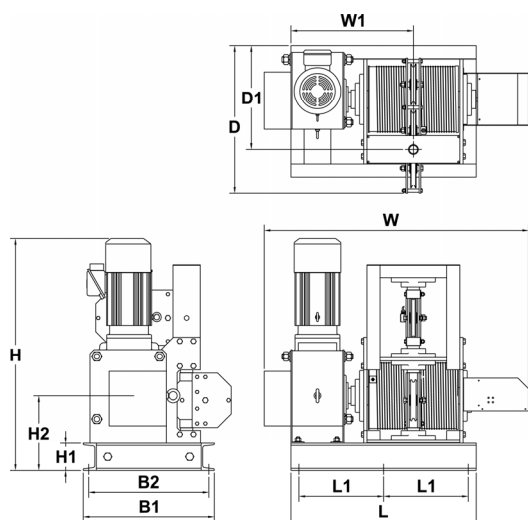

Model	L	L1	B1	B2	H1	H2	H	W	W1	D	D1
PH300A1E	630	290	480	440	100	275	760	910	448	542	380
PH500B1E	678	310	480	440	100	275	860	970	448	542	380

Macho Motorized Directional Point Winch is designed based on our widely used winch format whose reliability is solidly proven by significant project references, including TVB in Hong Kong and China Central Television (CCTV) in Beijing. The point winch consists of a set of swivel guide pulley and guard bars for wire drum which ensure zero-fleet angle for the output wire and being firmly keep the wire in right groove even lost pull force from the wire. It eases the installer/ designer to locate the winch at any position regardless the hoisting point. It is a general purpose winch suitable for applications in most stages, TV studios and malls. It is easy to install and once installed, no maintenance is required for years.

### Performance Data

Lifting Batten	Suitable for lifting light batten, truss, scenery bar
Hoisting Load	300Kg and 500Kg
Lifting Speed	Fixed speed approx. 0.2 m/sec
Lifting Lines	1 line
Manual bypass	Handle provided to manually wind the winch at motor end shaft
Lifting Travel	max. 20 meters
Safety factor	1.25 times

### Mechanical Data

Drum	Precision machined helically-grooved drum of Ø245mm, allow 3 dead wrap for the lift line with 2 keeper rollers to prevent slipping of steel wires
Gear Reducer	Single reduction worm-gear for continuous duty
Motor Brake	Spring applied and electrically released
Drawing Ropes	PH300A1E: Ø6mm steel wire rope (not included) PH500B1E: Ø8mm steel wire rope (not included)
Base Frame	C-channel welded together, painted in black
Cover	All rotating parts covered with safety guards

### Electrical Data

Brake Gear Motor	380V 3 phase 50Hz, with quick brake circuit integrated gear unit of size: PH300 1.5KW/ 85:1 gear PH500 2.2KW/ 85:1 gear
Main and Control input	380V 3phase 50Hz via 4 x 1.5mm <sup>2</sup> + GND (power) 2 x 1mm <sup>2</sup> 380VAC (for brake)
Load Cell	Optional
Safety Limit Switch	Adjustable mechanical upper and lower limit switch
Over-travel switch	Adjustable upper and lower over travel limit switch, separate circuit from safety limit switch

### Installation Data

Mounting method	Fix on structural platform by 6 x M10 bolt and nut at any orientation
Lift Line leaving drum direction	Within 90 degree from output guide pulley or directly downwards
Distance from drum to 1 <sup>st</sup> loft block or head pulley	No limitation

### Environmental Data

Operation humidity	5-95% non-condensing
Operation temperature	0-40°C (32-104°F)

### Physical and Ordering Data

Model	Ordering Number	Description	Net weight (Kg)	Gross weight (Kg)	Packing size (mm)
PH300A1E	TS20	300kg*20m*1pt	185	200	1,000*550*950
PH500B1E	TS10	500kg*20m*1pt	215	230	1,100*550*1,000

## Macho Drum Winch

**Macho DW X Y Z E**

- X:** Hoisting load in kg  
300/400/600/800
- Y:** Drum length  
A/B/C/D  
(refer table below)
- Z:** Lift lines  
4/6
- E:** Export version  
**L:** Local version  
**X:** Xtra version

**Macho DW300A4E** Motorized Drum Winch,  
Hoisting load 300kg, max  
5m travel, 4 lift lines,  
export version



Macho Drum Winch is designed based on our widely used winch format whose reliability is solidly proven by numerous project references. It is a general purpose winch suitable for applications in most stages and TV studios. The wire wraps neatly in a single layer on the steel drum to avoid damage. It can lift up to 15 meters high of max 6 lifting lines. It employs highly reliable worm-gear brake motor. It is easy to install and once installed, no maintenance is required for years.

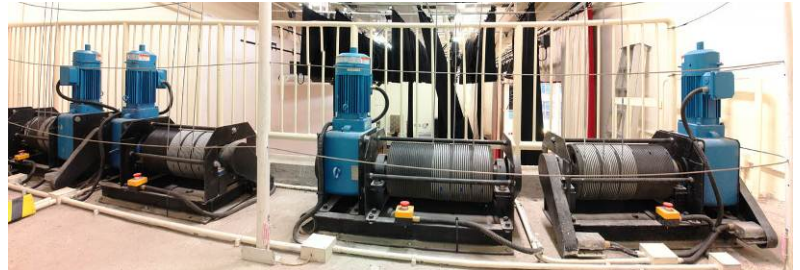

## Macho Drum Winch



## Macho Drum Winch Dwg (B Size)

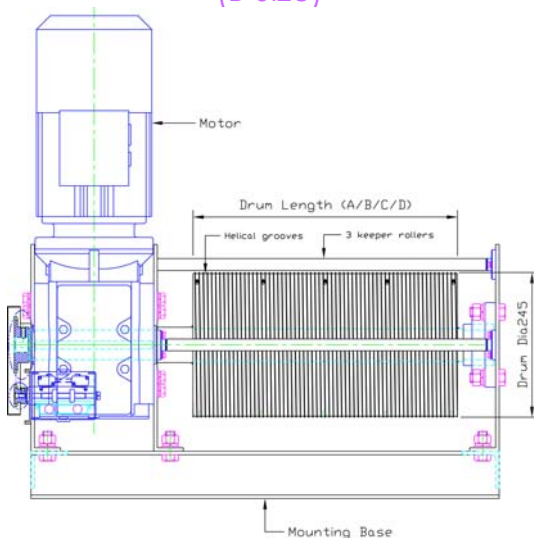

## Performance Data

Lifting Batten	Suitable for lifting light batten, truss, scenery bar
Hoisting Load	300/400/ 600/ 800 kg
Lifting Speed	Fixed speed approx. 0.2 m/sec
Lifting Lines	4/ 6 lines
Manual bypass	Handle provided to manually wind the winch at motor end shaft
Lifting Travel	5/ 10/ 15 m
Safety factor	1.25 times

## Mechanical Data

Drum	Precision machined helically-grooved drum of Ø245mm, in various length for different lifting travel and lift lines. Refer table below. <b>A size : 40 grooves</b> <b>B size : 64 grooves</b> <b>C size: 96 grooves</b> <b>D size: 135 grooves</b> (allow 3 dead wrap for each lift line) with 3 keeper rollers to prevent slipping of steel wires
Gear Reducer	Single reduction worm-gear for continuous duty
Support Side Plate	
Motor Brake	Spring applied and electrically released
Drawing Rope	Ø 5mm steel wire rope (not included)
Base Frame	
Cover	All rotating part covered with safety guard

## Electrical Data

Brake Gear Motor	380V 3 phase 50Hz, with quick brake circuit integrated gear unit of size: DW300 1.1kW/ 85:1 gear DW400 1.5kW/ 85:1 gear DW600 2.2kW/ 85:1 gear DW800 3.0kW/ 85:1 gear
Main and Control input	380V 3phase 50Hz via 4 x 1.5mm <sup>2</sup> + GND (power) 2 x 1mm <sup>2</sup> 380VAC (for brake)
Safety Switch	Adjustable mechanical upper and lower limit switch
Over-travel switch	Adjustable upper and lower over travel limit switch, separate circuit from safety limit switch

### Installation Data

Mounting method	Fix on structural platform by 4 x M8 bolt and nut at any orientation
Lift Line leaving drum direction	Any direction, recommend leaving at keeper roller position
Alignment	Wire drum to be centre aligned with loft blocks
Distance from drum to 1 <sup>st</sup> loft block or head pulley	To keep wire run smooth, distance has to keep sufficient distance from 1 <sup>st</sup> loft block to maintain recommended fleet angle

### Drum sizes (wire-travel length) Table

	4-lift-lines Drum size	6-lift-lines Drum size
5m lifting travel	<b>A</b>	<b>B</b>
10m lifting travel	<b>B</b>	<b>C</b>
15m lifting travel	<b>C</b>	<b>D</b>

### Payload for Drum Winch

Hoisting Load (Kg)	300	300	400	400	600	600	800	800
Lift Lines	4	6	4	6	4	6	4	6
Deadload of Steel Bar or Batten (Kg)	50	150	50	150	50	150	50	150
Payload (Kg)	250	150	350	250	550	450	750	650

Macostar reserves the right to change the specification without prior notice.  
Macostar International Ltd: Macho-drumwinch - DATA - V1.3-02 Sept 2011

### Environmental Data

Operation humidity	5-95% non-condensing
Operation temperature	0-40°C (32-104°F)

### Physical and Ordering Data

Model	Ordering Number	Description	Net weight (Kg)	Gross weight (Kg)	Packing size (mm)
DW300A4E	T11E	300kg* 5m*4pts	122	134	750*520*850
DW300B4E	T12E	300kg*10m*4pts	146	158	1020*520*850
DW300C4E	T13E	300kg*15m*4pts	178	190	1240*520*850
DW300B6E	T14E	300kg* 5m*6pts	146	158	1020*520*850
DW300C6E	T15E	300kg*10m*6pts	178	190	1240*520*850
DW300D6E	T16E	300kg*15m*6pts	220	232	1540*520*850
<b>DW400A4E</b>	<b>T21E</b>	<b>400kg* 5m*4pts</b>	<b>145</b>	<b>157</b>	<b>800*520*980</b>
<b>DW400B4E</b>	<b>T22E</b>	<b>400kg*10m*4pts</b>	<b>169</b>	<b>181</b>	<b>1070*520*980</b>
<b>DW400C4E</b>	<b>T23E</b>	<b>400kg*15m*4pts</b>	<b>201</b>	<b>213</b>	<b>1290*520*980</b>
<b>DW400B6E</b>	<b>T24E</b>	<b>400kg* 5m*6pts</b>	<b>169</b>	<b>181</b>	<b>1070*520*980</b>
<b>DW400C6E</b>	<b>T25E</b>	<b>400kg*10m*6pts</b>	<b>201</b>	<b>213</b>	<b>1290*520*980</b>
<b>DW400D6E</b>	<b>T26E</b>	<b>400kg*15m*6pts</b>	<b>224</b>	<b>236</b>	<b>1590*520*980</b>
DW600A4E	T31E	600kg* 5m*4pts	169	181	800*520*1020
DW600B4E	T32E	600kg*10m*4pts	193	206	1070*520*1020
DW600C4E	T33E	600kg*15m*4pts	225	238	1290*520*1020
DW600B6E	T34E	600kg* 5m*6pts	193	206	1070*520*1020
DW600C6E	T35E	600kg*10m*6pts	225	238	1290*520*1020
DW600D6E	T36E	600kg*15m*6pts	248	261	1590*520*1020
<b>DW800A4E</b>	<b>T41E</b>	<b>800kg* 5m*4pts</b>	<b>191</b>	<b>205</b>	<b>860*520*1060</b>
<b>DW800B4E</b>	<b>T42E</b>	<b>800kg*10m*4pts</b>	<b>215</b>	<b>229</b>	<b>1130*570*1060</b>
<b>DW800C4E</b>	<b>T43E</b>	<b>800kg*15m*4pts</b>	<b>247</b>	<b>261</b>	<b>1350*570*1060</b>
<b>DW800B6E</b>	<b>T44E</b>	<b>800kg* 5m*6pts</b>	<b>215</b>	<b>229</b>	<b>1130*570*1060</b>
<b>DW800C6E</b>	<b>T45E</b>	<b>800kg*10m*6pts</b>	<b>247</b>	<b>261</b>	<b>1350*570*1060</b>
<b>DW800D6E</b>	<b>T46E</b>	<b>800kg*15m*6pts</b>	<b>270</b>	<b>284</b>	<b>1650*570*1060</b>

Export Version: model # ending "E" (eg. DW300A4E),  
Domestic Version: model # ending "L" (eg. DW300A4L),  
Xtra Version (without motor): model # ending "X" (eg. DW300A4X),

## Macho Pile-Winding Winch

**Macho PW X Y Z E**

- X:** Hoisting load in kg  
300/500/800/1250
- Y:** Drum Plate Size A/B  
A/B  
(refer table below)
- Z:** Lift lines  
4/6
- E:** Export version

**Macho PW300B4E** Macho Pile-Winding Winch, Hoist load 300KG, max 15m travel, 4lift lines, export version

Macho Pile-Winding Winch is designed based on our widely used winch format whose reliability is solidly proven by numerous project references. It is a general purpose winch suitable for applications in most stages and TV studios. The wire coils neatly between drum plates in layers. It can lift up to 15 meters high of max 6 lifting lines. It employs highly reliable worm-gear brake motor. It is easy to install and once installed, no maintenance is required for years.



## Macho Pile-Winding Winch

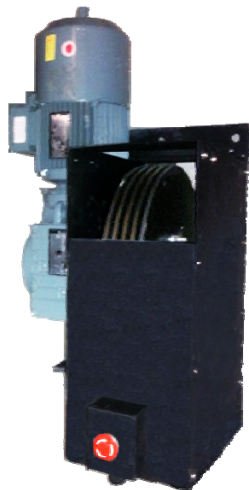

## Performance Data

Lifting Batten	Suitable for lifting light batten, truss, scenery bar
Hoisting Load	300/500/ 800/ 1250 kg
Lifting Speed	Average speed approx. 0.2 m/sec (0.08m/sec for 1250kg)
Lifting Lines	4/ 6 lines
Manual bypass	Handle provided to manually wind the winch at motor end shaft
Lifting Travel	10/ 15 m

## Macho Pile-Winding Winch Dwg

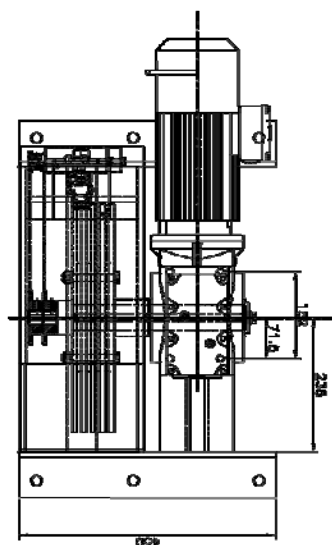

## Mechanical Data

Drum	Precision machined steel drum plate of Ø350mm (A size / Ø400mm (B size) for different lifting travel (allow 3 dead wrap for each lift line)
Gear Reducer	Single reduction worm-gear for continuous duty
Motor Brake	Spring applied and electrically released
Drawing Rope	Ø 6mm steel wire rope (not included)
Cover	All rotating part covered with safety guard

## Electrical Data

Brake Gear Motor	380V 3 phase 50Hz, with quick brake circuit integrated gear unit of size: PW300 1.5kW/ 86:1 gear - PW500 2.2kW/ 86:1 gear SA87 DV100L4BMG/HR/2WE PW800 3.0kW/ 99:1 gear - PW1250 2.2kW/230:1 gear SA97 DV100L4BMG/HR/2WE
Main and Control input	380V 3phase 50Hz via 4 x 1.5mm <sup>2</sup> + GND (power) 2 x 1mm <sup>2</sup> 380VAC (for brake)
Safety Switch	Adjustable mechanical upper and lower limit switch
Over-travel switch	Adjustable upper and lower over travel limit switch, separate circuit from safety limit switch



### Installation Data

Mounting method	Fix on structural platform by 4 x M8 bolt and nut at any orientation
Lift Line leaving Pile -Winding drum direction	Any direction in the rotation plane
Alignment	Wire to be aligned with loft blocks
Distance from drum to 1 <sup>st</sup> loft block or head pulley	**No minimum distance requirement**

### Pile- Winding Plate Sizes (wire-travel length) Table

	Drum Plate size
10m lifting travel	<b>A</b>
15m lifting travel	<b>B</b>

### Payload for Pile- Winding Winch

Hoisting Load (Kg)	300	300	500	500	800	800	1250	1250
Lift Lines	4	6	4	6	4	6	4	6
Deadload of Steel Bar or Batten (Kg)	50	150	50	150	50	150	50	150
Payload (Kg)	250	150	450	350	750	650	1200	1100

### Environmental Data

Operation humidity	5-95% non-condensing
Operation temperature	0-40°C (32-104°F)

### Physical and Ordering Data

Model	Ordering Number	Description	Net weight (Kg)	Gross weight (Kg)	Packing size (mm)
PW300A4E		300kg* 10m*4lines			1000*650*650
PW300A6E		300kg* 10m*6 lines			1000*650*650
PW300B4E		300kg* 15m* 4 lines			1000*650*650
PW300B6E		300kg* 15m* 6 lines			1000*650*650
PW500A4E		500kg* 10m* 4 lines			1130* 650* 650
PW500A6E		500kg* 10m*6 lines			1130* 650* 650
PW500B4E		500kg* 15m* 4 lines			1130* 650* 650
PW500B6E		500kg* 15m* 6 lines			1130* 650* 650
PW800A4E		800kg* 10m* 4 lines			1200* 650* 650
PW800A6E		800kg* 10m*6 lines			1200* 650* 650
PW800B4E		800kg* 15m* 4 lines			1200* 650* 650
PW800B6E		800kg* 15m* 6 lines			1200* 650* 650
PW1250A4E		1250kg* 10m* 4 lines			1270* 650* 650
PW1250A6E		1250kg* 10m*6 line			1270* 650* 650
PW1250B4E		1250kg* 15m* 4 line			1270* 650* 650
PW1250B6E		1250kg* 15m* 6 lines			1270* 650* 650

Macostar reserves the right to change the specification without prior notice.  
Macostar International Ltd: Macho-PileWind - DATA - V1.1 - 14 Jul 2012

## Draw Curtain Machine

Macho DCM15	Draw Curtain Machine for max 15m wide c/w (1) control station
Macho DCM25	Draw Curtain Machine for max 25m wide c/w (1) control station



Our new Macho series member, Macho Draw Curtain Machine, provides the automatic control for the Front curtain in most stages. It can operate bi-parting curtain system of up to 25m wide. It employs a highly reliable, compact and efficient Japanese motor. It is easy to install and once installed, no maintenance is required for years.



## Macho Draw Curtain Machine



### Macho DCM15

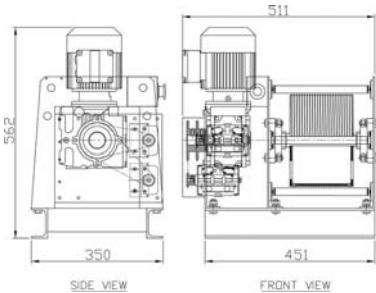

### Macho DCM25

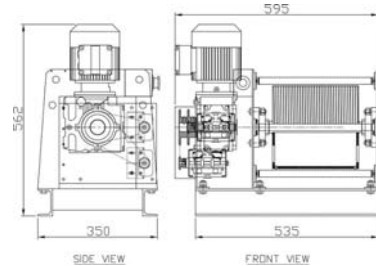

## Operation Data

Curtain Track	Suitable for bi-parting, straight or curved curtain track (e.g. H&H 300 or 500 series)
Cable Speed	0.45m/sec
Control Station	Open, Stop and Close Button; When Open/ Close button is pressed, motor runs latched until limit switch reached or Stop button pushed. (one station supplied together with machine.)
Electrical connection	Circuits via multi-core cable attached by the cable gland to the top/ bottom of the end connector box and connected to the terminals inside.

## Mechanical Data

Drum	Precision machined Helically-grooved drum of Ø245mm, in various length: DCM15: 23 grooves DCM25: 35 grooves with spring-loaded cable tension device acted on guide-pulleys, mounted to heavy steel channel base
Output Torque	90 Nm
Gear Reducer	1:40 Single reduction hyponic gear for continuous duty
Drawing Rope	Ø 5mm steel wire rope, with 3 dead wraps at drum

## Electrical Data

Gear Motor	0.4kW, 1:40 gear, 380V 3 phase 50Hz
Main and Control input	380V 3phase 50Hz via 4 x 1.5mm <sup>2</sup> + GND (power) 3 x 1mm <sup>2</sup> 24VDC (for control station)
Safety Switch	Adjustable mechanical open and close limit switch
Motor control box	With 3 phase isolator, contactor overload protection, mechanical and electrical interlocks, 24VDC control circuit, local push button control, E-stop

## Environmental Data

Operation humidity	5-95% non-condensing
Operation temperature	0-40°C (32-104°F)

## Physical Data

Model	DCM15	DCM25
Net weight (kg)	65	70
Gross weight (kg)	65	80
Packing size (mm)	520*430*720	580*430*720

## Ordering Information

Model	Order number
DCM15	TG10
DCM25	TG20

## Installation Data

Mounting method	Fix on structural platform by 4 x M8 bolt and nut
Alignment	To be centre aligned with curtain track; guide-pulley around 400mm below track double end pulley
Distance from drum to track double end pulley	To keep wire run smooth, distance has to be maintained as below: DCM15: 1600mm DCM25: 2700mm

### Draw Curtain Machine OT

Macho DCMOT5	Draw Curtain Machine (on Track 500 series) c/w (1) control station
Macho DCMOT4	Draw Curtain Machine (on Track 400 series) c/w (1) control station
Macho DCMOT3	Draw Curtain Machine (on Track 300 series) c/w (1) control station

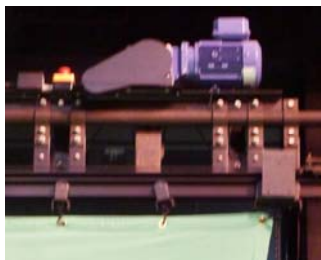

Our new Macho series member, Macho Draw Curtain Machine – on Track type, provides the automatic control for the Front curtain in most stages. It can be installed on curtain track to save space and operate bi-parting curtain system up to 30m wide. It employs highly reliable, compact and efficient Japanese motor. Once installed, it requires no maintenance for years.



### DCMOT5

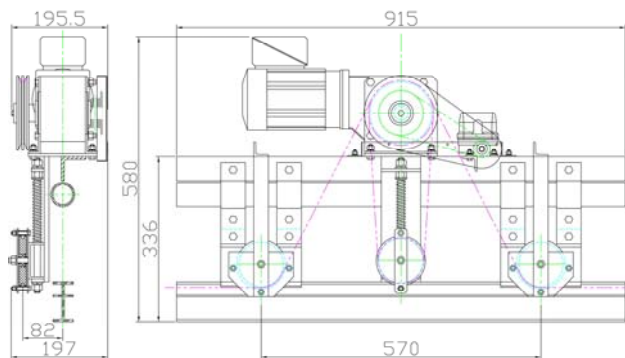
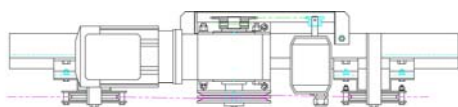

### Operation Data

Curtain Track	Suitable for bi-parting, straight curtain track only. (e.g. H&H 300, 400 or 500 series)
Cable Speed	0.45 m/sec
Control Station	Open, Stop and Close Button; when Open / Close button is pressed, motor runs latched until limit switch reached or Stop button pushed. (one station supplied together with machine.)
Electrical connection	At motor control box and connected to the terminals inside.

### Mechanical Data

Drive Pulley	Ø150mm cast iron drive pulley with double V-groove, with spring-loaded ball bearing idler to maintain cable tensions
Structure	Machine secured to fabricated steel base designed to attach onto Ø48.3mm pipe batten Two Ø 100mm ball bearing pulleys to align operating cable with curtain track
Output Torque	105 Nm
Gear Reducer	1:25 Single reduction hypnotic gear for continuous duty
Drawing Rope	Ø 5mm steel wire rope

### Electrical Data

Gear Motor	0.75kW, 1:25 gear, 380V 3 phase 50Hz
Main and Control input	380V 3 phases 50Hz via 4 x 1.5mm <sup>2</sup> + GND (power) 3 x 1mm <sup>2</sup> 24VDC (for control station)
Safety Switch	Adjustable mechanical open and close limit switch
Motor control box	With 3 phases isolator, contactor overload protection, mechanical and electrical interlocks, 24VDC control circuit, local push button control and E-stop

### Installation Data

Mounting method	Attach onto Ø48mm pipe batten above curtain track
Alignment	To be centre aligned with curtain track

### Environmental Data

Operation humidity	5-95% non-condensing
Operation temperature	0-40°C (32-104°F)

### Ordering Information

Model	Ordering No.
DCMOT5	TG30
DCMOT4	TG40
DCMOT3	TG50

Macostar reserves the right to change the specification without prior notice.  
Macostar International Ltd: Macho-drawcmOT -DATA -V1.1 – 25 Jul 2012

## Macho Studio Hoist

Macho SH-4000 4-meter motorized lighting hoist.



The Macho Studio Hoist is a combination of gear brake motor and control, aluminium tracks, drop pulley, flat cables and basket, output sockets for luminaire, safety switches as well as lifting ropes. The compact and rigid Macho studio hoist is designed for easy installation for payloads up to 150Kg.



### Performance Data

Travel	10 m
Closed Height	880 mm
Average Lifting Speed	0.1m/ sec
Max Payload	150 kg.

### Installation Data

Mounting method	By barrel clamps at evenly spaced suspension points
Support separation	Max. 3m separation between suspension points.
Electrical connection	Circuits via multi-core cable attached by the cable gland to the top/ bottom of the end connector box and connected to the terminals inside.

### Environmental Data

Operation humidity	5-95% non-condensing
Operation temperature	0-40°C (32-104°F)

### Physical Data

Model	Macho SH-4000
Net weight	95Kg
Gross weight	110Kg
Packing size(mm)	4500W*200D*1200H

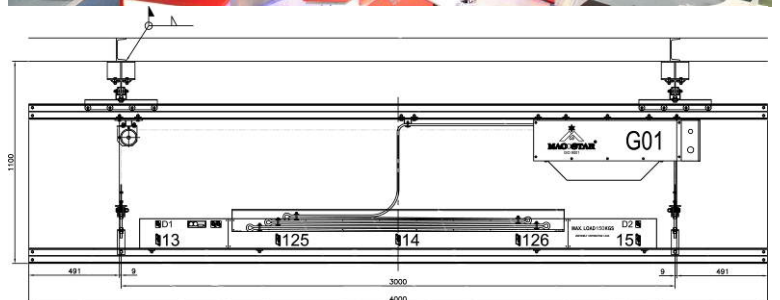

### Mechanical Data

Top	4m black anodized aluminium E8 track with end stop fitted with motor box, cable box and drop pulley
Bottom	4m black anodized aluminium E8 track with end stop (option: Ø48mm black anodized aluminum barrel with end stop)
Motor and control Box	Clipped to E8 track by 10 x M8 bolt and nut
Cable Box	Clipped to E8 track by 4 x M8 bolt and nut
Drop pulley	Clipped to E8 track by 4 x M8 bolt and nut, Ø150mm
Lifting Rope	4 x Ø 4mm steel wire rope

### Electrical Data

Gear Brake Motor	1.5kW, 1:100 worm gear, 380V 3 phase 50Hz
Main and Control input	5A 380V 3phase 50Hz via 4 x 2.5mm <sup>2</sup> (Starting Current: 17A) + GND (power) 3 x 1mm <sup>2</sup> 24VDC (control)
Safety Switch	Adjustable upper and lower limit switch Slack wire detector switch Over travel limit switch
Output Circuits	3 x 16A lighting circuits with 3 x 16A CEE17 female socket per circuit 1 x 16A general circuit with 1 x 13A UK socket 1 x DMX circuit with 1 x iDOP DMX output port (24VDC required)
Flat Cable	12 x 2.5mm <sup>2</sup> rubber flat cable + 1 x DMX cable bound by pressing clips at turning ends at increasing interval
Cable Box	Screw pressing terminals for 4mm <sup>2</sup> cable + DMX terminals
Motor control box	At the end of motor box for easy installation With contactor overload protection, 3 phase isolator, 24VDC control circuit, E-stop

### Macho Winch Control Box

**Macho MC-TMC-1** Winch Control Box, fixed Speed for motor max 4KW

**Macho HC-100** One-Action Pendant

#### Winch Control Box

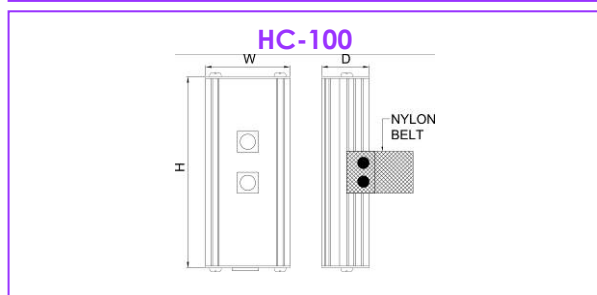
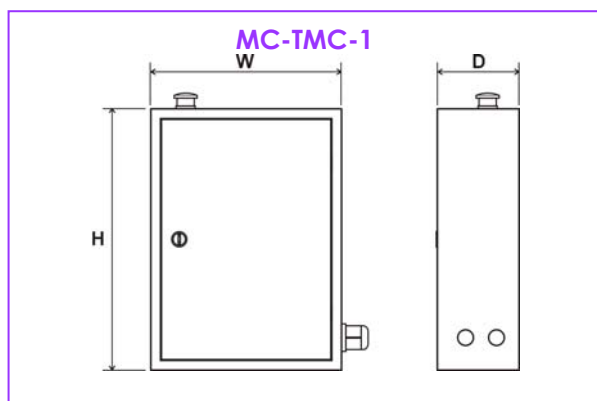

#### Environmental Data

Operation humidity	5-95% non-condensing
Operation temperature	0-40°C (32-104°F)
Installation place	indoor

#### Physical Data

Model	MC-TMC-1	HC-100
Weight (kg)	22.5kg	0.3kg
Size (mm)	W / H / D 480*560*200	W / H / D 72*164*40

#### Ordering Information

Model No.	Ordering No.
Macho MC-TMC-1	E410
Macho HC-100	E3A0

Macho Winch Control Box is designed for driving only fixed speed winch under 4kW and being able to monitor up to 9 status/alarms of the winch. It works with Macho Winch Control Console perfectly to form a flexible and full functions rigging control system for TV studios, theatres and architectural applications. It targets for venues that require high reliability for rigging system and manual bypass backup. It is also designed for easy wiring and installation.

#### Mechanical Data

Construction	Zinc anodized steel sheet, with hinge door
Paint / finish	Black epoxy-polyester powder paint
Mounting	Wall mounted by 4 x M8 screws
Both Sides	2 x dia.33mm hole for conduits on both sides
Bottom	76x150mm hole for cable containment

#### Electrical Data

Power input	380VAC~420VAC three phases four wires plus earth
Frequency	50Hz
Main Input	Max 6A per phase, max 4kW motor
Control circuit	24V AC
Input Connector	4mm² terminals
Output Connector	4mm² terminals
Control Bus	Macho Hoist Control Bus (Macho Bus) in CAN BUS

#### Operational Data

Monitor winch signals (relay signal)	<ol style="list-style-type: none"> <li>System e-stop</li> <li>Local e-stop</li> <li>Power fault (missing phase, over/under voltage, overload)</li> <li>Over travel limit</li> <li>Slack Wire detector</li> <li>High Limit</li> <li>Low Limit</li> </ol>
Monitor winch signals (load cell)	<ol style="list-style-type: none"> <li>Loading (range 50kg – 1000kg)</li> <li>Position</li> </ol>
Starting address	Set by 10 dip switches, allowable address: 1024
Local e-stop	At top of Box
Mode Selector	Auto/ Idle/ Local
Local Control	Via 5-pin XLR male receptacle at top, to connect handheld One-Action Pendant
Indicator Lights	Power/ Mode/ Bus/ Up/ Down/ Fault
Syn in Group	Auto fine tune to same position as Master unit in the same Group (Winch to have position encoder installed and using our Macho Hoist Control System)

#### Wiring Connection

Input power	5 x 4 mm²
Output power	5 x 4 mm²
System e-stop	2 x 1 mm², 24V AC
Local e-stop	2 x 1 mm², 24V AC
Power fault	2 x 1 mm², 24V AC
Over Travel Limit	2 x 1 mm², 24V AC
Slack Wire Detector	2 x 1 mm², 24V AC
High Limit	2 x 1 mm², 24V AC
Low Limit	2 x 1 mm², 24V AC
Loading	4/C Twisted pair, 12V DC
Position	6/C Twisted pair, 12V DC
Macho Bus	4/C Twisted pair, 12V DC

#### Safety Features

Power Failure	Last action stop running (at Auto Mode)
Safety Protection	<ol style="list-style-type: none"> <li>Hardwire interlock</li> <li>Software interlock</li> <li>Intelligent logic: <ul style="list-style-type: none"> <li>high limit reach, down action allow only;</li> <li>low limit reach, slack wire and up action allow only</li> </ul> </li> <li>Optical-isolated for all input connections</li> </ol>
Position Memory	Value retained even power failure

### Macho Winch Control Box

**Macho MC-TMC-5**

Winch Control Box,  
variable Speed

**Macho HC-100**

One-Action Pendant

#### Winch Control Box

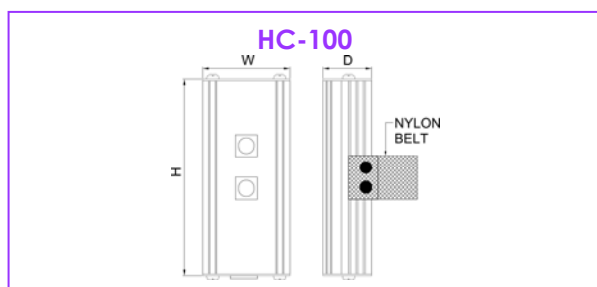
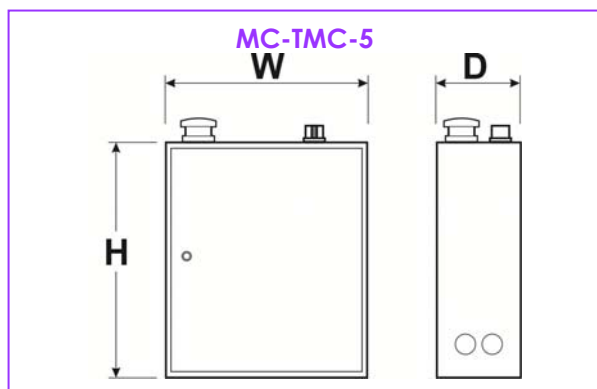

#### Environmental Data

Operation humidity	5-95% non-condensing
Operation temperature	0-40°C (32-104°F)
Installation place	indoor

#### Physical Data

Model	MC-TMC-5	HC-100
Weight	22.5kg	0.3kg
Size mm	W / H / D 480*560*200	W / H / D 72*164*40

#### Ordering Information

Model No.	Ordering No.
Macho MC-TMC-5	E4W0
Macho HC-100	E3A0

Macho MC-TMC-5 control box is designed for driving flag raising winch under 4kW in variable speed and being able to monitor up to 9 status/alarms of the winch. It works with Macho Winch Control Console perfectly to form a flexible and full functions rigging control system for stadium and swimming pools applications. It targets for venues that require high reliability for rigging system and manual bypass backup. It is also designed for easy wiring and installation.

#### Mechanical Data

Construction	Zinc anodized steel sheet, with hinge door
Paint / finish	Black epoxy-polyester powder paint
Mounting	Wall mounted by 4 x M8 screws
Both Sides	2 x dia.33mm hole for conduits on both sides
Bottom	76x150mm hole for cable containment

#### Electrical Data

Power input	380VAC~420VAC three phases four wires plus earth
Frequency	50Hz
Main Input	Max 6A per phase, max 4kW motor
Control circuit	24V AC
Input Connector	4mm <sup>2</sup> terminals
Output Connector	4mm <sup>2</sup> terminals
Control Bus	Macho Hoist Control Bus (Macho Bus) in CAN BUS

#### Operational Data

Monitor winch signals (relay signal)	<ol style="list-style-type: none"> <li>System e-stop</li> <li>Local e-stop</li> <li>Power fault (missing phase, over/under voltage, overload)</li> <li>Over travel limit</li> <li>Slack Wire detector</li> <li>High Limit</li> <li>Low Limit</li> </ol>
Monitor winch signals (load cell)	<ol style="list-style-type: none"> <li>Loading (range 50kg – 1000kg)</li> <li>Position</li> </ol>
Frequency inverter	Operate range 25Hz-60Hz
Starting address	Set by 10 dip switches, allowable address: 1024
Local e-stop	At top of Box
Mode Selector	Auto/ Idle/ Local
Local Control	Via 5-pin XLR male receptacle at top, to connect handheld One-Action Pendant
Indicator Lights	Power/ Mode/ Bus/ Up/ Down/ Fault
Syn in Group	Auto fine tune to same position as Master unit in the same Group (Winch to have position encoder installed and using our Macho Hoist Control System)
Control compatibility	Work with FCS-180 or FCS-PC flag raising control

#### Wiring Connection

Input power	5 x 4 mm <sup>2</sup>
Output power	5 x 4 mm <sup>2</sup>
System e-stop	2 x 1 mm <sup>2</sup> , 24V AC
Local e-stop	2 x 1 mm <sup>2</sup> , 24V AC
Power fault	2 x 1 mm <sup>2</sup> , 24V AC
Over Travel Limit	2 x 1 mm <sup>2</sup> , 24V AC
Slack Wire Detector	2 x 1 mm <sup>2</sup> , 24V AC
High Limit	2 x 1 mm <sup>2</sup> , 24V AC
Low Limit	2 x 1 mm <sup>2</sup> , 24V AC
Loading	4/C Twisted pair, 12V DC
Position	6/C Twisted pair, 12V DC
Macho Bus	4/C Twisted pair, 12V DC

#### Safety Features

Power Failure	Last action stop running (at Auto Mode)
Safety Protection	<ol style="list-style-type: none"> <li>Hardwire interlock</li> <li>Software interlock</li> <li>Intelligent logic: <ul style="list-style-type: none"> <li>high limit reach, down action allow only;</li> <li>low limit reach, slack wire and up action allow only</li> </ul> </li> <li>Optical-isolated for all input connections</li> </ol>
Position Memory	Value retained even power failure

## Macho Signal Distribution Rack

**Macho SDR-3** 3-Way Ethernet to CAN signals converter

### Signal Distribution Rack



### SDR-3 Internal view and Drawing



### Macho SDR-3 Schematic diagram

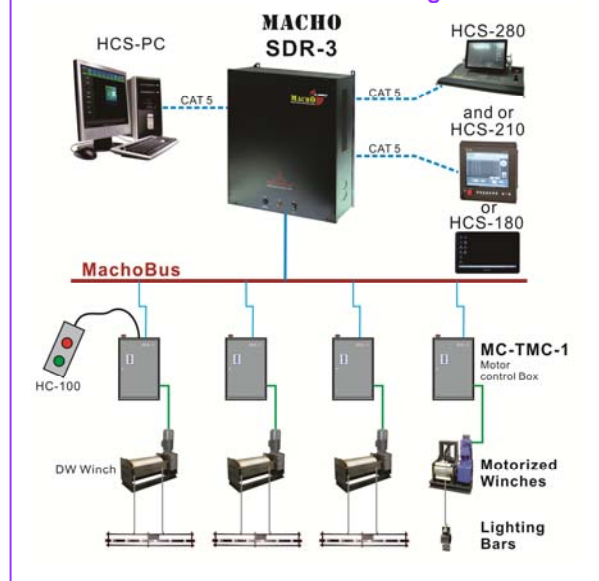

Macho Signal Distribution Rack is a centralized signal distribution rack designed for Macho Hoist Control System. The unit could support three sets of Macho Hoist Control panels at the same time converting Ethernet to CAN signals. The SDR-3 provides three Ethernet connectors providing interfaces for Macho Hoisting Control Systems such as HCS-PC, HCS-280, HCS-210 and HCS-180 wired and wireless equipment.

### Mechanical Data

Construction	Zinc anodized steel sheet
Paint / finish	Black epoxy-polyester powder paint
Mounting	Wall mounted by 4 x M8 screws
Power & signal outlets	2 x dia.33mm hole for conduits on top, bottom and both sides

### Electrical Data

Power input	100~240VAC Single phase
Frequency	50 / 60Hz
Current	1A
Power consumption	70W

### Operational Data

Connection	3 x POE Ethernet RJ45 connectors; 1 x MachoBUS terminal
Ethernet	100Mbps/1,000Mbps
MachoBUS	CANBUS 100Kbps
Network	Seamless operation across Ethernet and MachoBUS

### Environmental Data

Operation humidity	0 - 95% non-condensing
Operation temperature	0-40°C (32-104°F)
Installation place	indoor

### Physical Data

Weight	7.8 kg
Size mm	W / H / D 380*458*92
Mounting screws centre distance	Horizontal 359mm Vertical 442mm

### Ordering Information

<b>Model No.</b>	<b>Ordering No.</b>
Macho SDR-3	E4Z0

Macostar reserves the right to change the specification without prior notice.  
Ref: Macho-SDR-3 - V1.2 - 18 Jul 2013

### Macho Flag Raising Control PC

**Macho FCS-PC** Flag Raising control PC

### Macho FCS-PC



FCS-PC is a member of Macho Hoist Control System designed for flag raising ceremonies. The FCS-PC is the PC based controller at control room connects to Macho Flag Raising Drum Winch through Ethernet. The National anthem in MP3 format is loaded into it and played with flag control. It can operate the flag raising at a range of speeds from 0.18 to 0.45 meter per second.



### Software Features

- ✦ Adjust raising speed (0.18~0.45m/s, by Macho FDW150C5E) to suit different length of National anthem
- ✦ Synchronize raising action with playing anthem
- ✦ Control sequence as per presentation procedures
- ✦ Auto calibration for different height in different stadium
- ✦ Auto/manual operation mode selection
- ✦ Actual height indication
- ✦ Allow delay start & early stop timer setting
- ✦ Can select any one flag to control among max. 5 flags in the system
- ✦ Have to work with Macho Winch Control Box MC-TMC-5
- ✦ Can work with FCS-180 as wireless remote
- ✦ Chinese/ English interface for selection
- ✦ Graphical GUI Display for easy operation
- ✦ Adjustable presets for start & stop positions

### Hardware Features

Processor	Intel Core i5, 3.0GHz
OS	Windows 7, 64 Bit
RAM	SDRAM 4GB
Hard Disk	500GB
Display	21.5" LED Display
Drive	DVD +/-RW 16X
I/O ports	Gigabit Ethernet / VGA / 4xUSB / 3.5mm headphone & mic jacks / HDMI out
Power supply	220V 50Hz
Dimension (mm)	174(W) * 370(H)* 436(D), for PC

### Ordering Data

Model	Ordering No
FCS-PC	E4V0

## MACHO

### FCS Flag Raising System

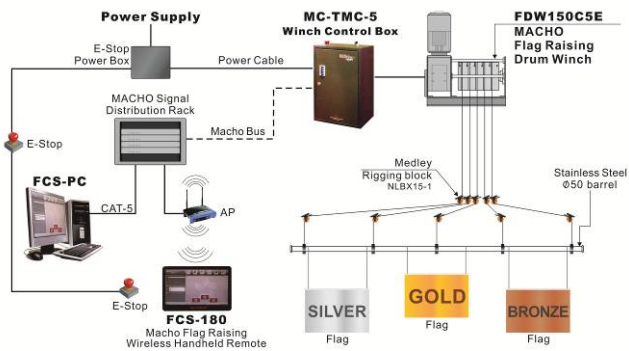

Macostar reserves the right to change the specification without prior notice.  
Ref: Macho-flagPC - DATA - V1.2 - 18 Jul 2013

### Macho Flag Raising Control

**Macho FCS-180** Flag Raising wireless Handheld Remote

### Macho FCS-180



FCS-180 is a member of Macho Hoist Control System designed for flag raising ceremonies. The FCS-180 is a wireless handheld remote controller connects to Macho Flag Raising Drum Winch through WiFi network. The system controls flags raising at a range of speeds from 0.18 to 0.45 meter per second.



### MACHO

#### FCS Flag Raising System

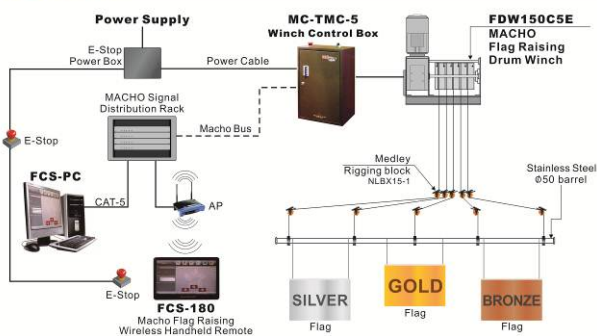

### Software Features

- ✧ Adjust raising speed (0.18~0.45m/s, by Macho FDW150C5E) to suit different length of National anthem.
- ✧ Synchronize raising action with playing anthem
- ✧ Control sequence as per presentation procedures
- ✧ Auto calibration for different height in different stadium
- ✧ Auto/manual operation mode selection
- ✧ Actual height indication
- ✧ Allow delay start & early stop timer setting
- ✧ Graphical GUI Display for easy operation
- ✧ Adjustable presets for start & stop positions
- ✧ Can select any one flag to control among max. 5 flags in the system
- ✧ Have to work with Macho Flag Raising Control PC FCS-PC and Winch Control Box MC-TMC-5
- ✧ Chinese/ English interface for selection

Macostar reserves the right to change the specification without prior notice.  
Ref: Macho-flagwifi - DATA - V1.2 - 18 Jul 2013

### Hardware Features

Processor	Intel Celeron, BGA956
Video clip	Intel GMA X4500
RAM	DDR2 1GB
Hard Disk	250GB
Display	10.1" 1024x600 LCD Touch display LED backlight, Capacitive 2-point touch technology
Camera	130m pixel
Wireless	802.11 b/g, Bluetooth
Battery	4800mAh Rechargeable Polymer Lithium ion battery
Audio	Internal speaker & mic
I/O ports	DC IN / USB2.0x2 / 3.5mm headphone jack / mic jack / mini HDMI
Ext. power supply	AC100~240V, 50/60Hz, 19V 3.42A output
Dimension	253 x 168 x 18mm
Weight	0.96Kg
Certified	CE, FCC, CCC

### Ordering Data

Model	Ordering No
FCS-180	E4X0

### Macho Flag Raising Drum Winch

**Macho FDW150C5E** Motorized Drum Winch,  
Hoisting load 150kg,  
max 12m travel,  
5 lift lines,

### Macho Drum Winch



Macho Flag Raising Drum Winch is designed based on our widely used winch format whose reliability is solidly proven by numerous project references. It is a purpose made winch suitable for applications in most stadium for National Flag Raising. The wire wraps neatly in a single layer on the steel drum to avoid damage. It can lift up to 12 meters high of max 5 lifting lines. It is easy to install and once installed, no maintenance required for years.



### Performance Data

Lifting Batten	Suitable for lifting flag barrels
Hoisting Load	150 kg
Lifting Speed	0.18~0.45 m/sec
Lifting Lines	5 lines
Manual bypass	Handle provided to manually wind the winch at motor end shaft
Lifting Travel	12 m
Safety factor	1.25 times

### Mechanical Data

Drum	Precision machined helically-grooved drum of Ø245mm with 3 keeper rollers to prevent slipping of steel wires.
Gear Reducer	Single reduction worm gear for continuous duty
Support Side Plate	Rigidly constructed 6mm thick side plate mounted with heavy duty steel ball bearing providing full support and smooth running for the drum winch.
Motor Brake	Spring applied and electrically released
Drawing Rope	Ø 3mm steel wire rope (not included)
Base Frame	80*43*6.5mm U-beam construction, standard mounting holes on frame ready for on-site installation.
Cover	All rotating part covered with safety guard

### Electrical Data

Brake Gear Motor	380V 3 phase 50Hz, with integrated gear unit of size 1.1kW/ 49:1 gear
Main and Control input	380V 3phase 50Hz via 4 x 1.5mm <sup>2</sup> + GND (power) 2 x 1mm <sup>2</sup> 230VAC (for brake)
Encoder	Absolute encoder for positioning
Safety Switch	Adjustable mechanical upper and lower limit switch
Over-travel switch	Adjustable upper over travel limit switch, separate circuit from safety limit switch

### Environmental Data

Operation humidity	5-95% non-condensing
Operation temperature	0-40°C (32-104°F)

### Installation Data

Mounting method	Fix on structural platform by 4 x M8 bolt and nut at any orientation
Lift Line leaving drum direction	Any direction, recommend leaving at keeper roller position
Alignment	Wire drum to be centre aligned with loft blocks
Distance from drum to 1 <sup>st</sup> loft block or head pulley	To keep wire run smooth, distance has to keep sufficient distance from 1 <sup>st</sup> loft block to maintain recommended fleet angle

### Physical and Ordering Data

Model	Ordering Number	Description	Net weight (Kg)	Gross weight (Kg)	Packing size (mm)
FDW150C5E		150kg* 12m* 5pts	122	134	750*520*850

### Macho Flag Raising Drum Winch Dwg

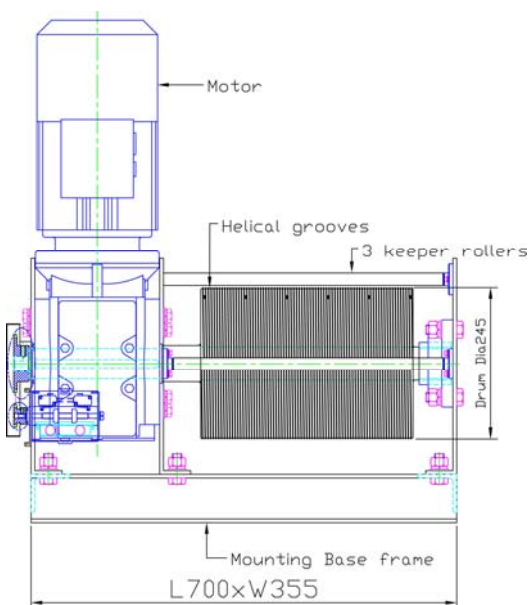

Blank page

**Macho Hoist Control System**

**MACHO HCS 280C 21.5" Touchscreen  
Hoist Control Console**



2011  
香港工商業獎  
HONG KONG AWARDS  
FOR INDUSTRIES

機器及機械工具設計獎  
MACHINERY AND MACHINE  
TOOLS DESIGN AWARD

Winning product:

**Macho Hoist Controller**  
**麥哲歐舞動控制台**

HCS 280C- Front View



Rear View



**Product Features**

Control motions	Up, down and emergency stop
Safety alarms	* Position monitoring * Emergency stop * Over current * Over weight * Over travel limit * Logical upper/lower limits * Physical upper/lower limits * Slack wires
System Control	1) Administrator: * Create & edit hoist system design * Account management for Operator level * Preset hoist system status 2) Operator: * Control the preset system
Hoist Control	1) Individual 2) Groups * Group assign or edit * Group labeling * Automatic movement

HCS-280C is a member of Macho Hoist Control System designed for TV studios and medium to large sized theatres. The HCS-280C is a countertop console which controls up to 255 motorized winches including a number of variable speed motorized winches. The LCD touch screen allows any user to familiarize to it quickly. It also uses Motion-Status Arithmetic Engine (MSAE) to intelligently provide precise controlled response times. The flexible grouping control caters to the need for automatic movement and group assignment, label, or edit. The multi-level login provides administrator and operator to have different access to the system which also prevents unauthorized use.



**Mechanical Data**

Construction	Extruded aluminum top and bottom edges together with Light weight rigid aluminum alloy sheets construction.
Paint / finish	Dark grey epoxy-polyester powder paint
Touchscreen	Adjustable tilting view angle

**Electrical Data**

Power input	200V~240VAC; ON/OFF switch and START press button
Frequency	50 ~ 60 Hz
Motors	Max. 255 motors per system
Ethernet port	RJ45 socket
Emergency-stop	Local: front panel; remote: female XLR 3-pin socket
Cooling fan	Yes

**Display Data**

Screen	21.5", 16:9 TFT resistive touchscreen, adjustable angle
Resolution	1920 X 1080
Contrast	1000 : 1
Viewing angles	H 170° / V 160°

**Operational Data**

Touch screen	Full functions operation
Keyboard	14 GROUP buttons for grouping shortcut with back lights; 0-9 numeric buttons with back lights; Cursor buttons with back lights; CLEAR button with back light; ENTER button with back light; Joystick for UP and DOWN hoist movement control; ON/OFF key for keyboard lock; E-stop button for emergency power cut off to all motors connected to the system.
Network	Ethernet connection available
System security	Two levels password access to the system: 1) administrator 2) operator

**Installation Data**

Mounting method	Countertop console, no mounting required
Power connection	Connect to a 220VAC wall socket with IEC power cord

**Environmental Data**

Operation humidity	5-95% non-condensing
Operation temperature	0-40°C (32-104°F)
Installation place	indoor

**Standards**

CE LVD directives and standards complied	
CE EMC directives and standards complied	

**Physical Data**

Model	HCS 280 / 280C
Weight)	26kg
Size (mm)	W / H / D 970 * 430 * 505

**Ordering Information**

Model No.	Ordering number
HC 100	E3A0
HCS 210	
HCS 210C	
HCS 280	
HCS 280C	
MC-TMC-1	E410
MC-PSC-2	W450

HCS ~C= Console Server version

HCS 280C dimension drawing

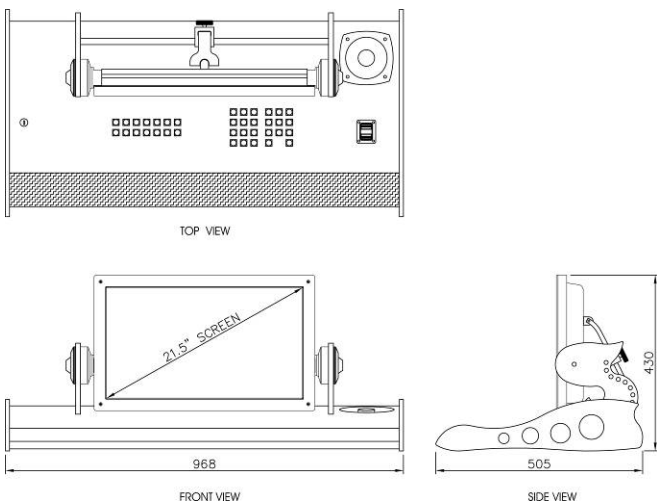

Macostar reserves the right to change the specification without prior notice.  
Macostar International Ltd: Macho-HCS280 - DATA - V1.4 -14 Jul 2012

Macho HCS schematic diagram

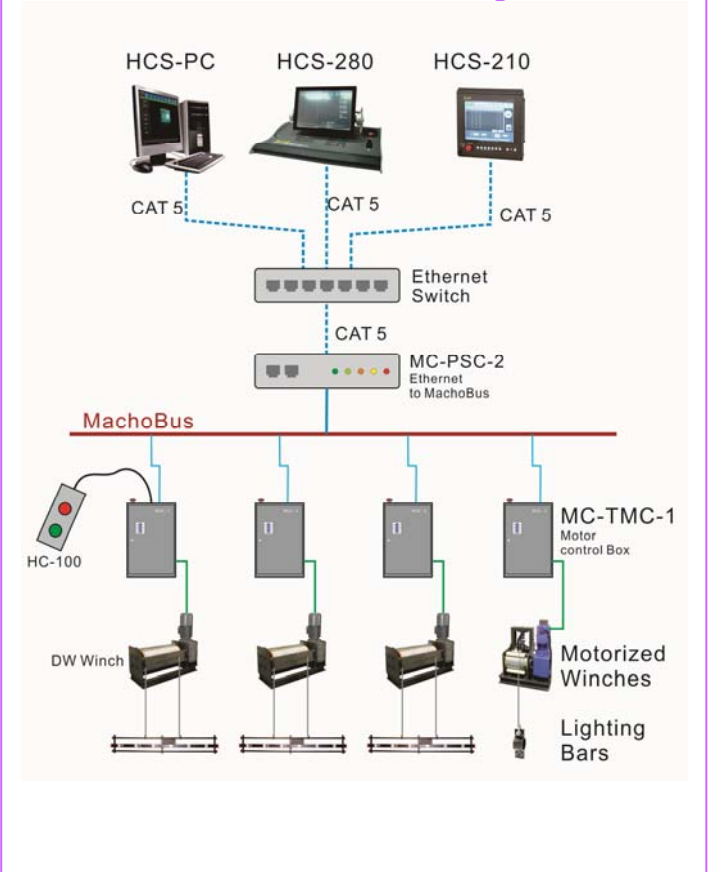

### Macho Hoist Control System

**MACHO HCS 210 17" Touch screen wall mount Hoist Control panel**



HCS 210 - front view



HCS 210 - rear view



HCS-210 is a member of Macho Hoist Control System designed for TV studios and small to medium sized theatres. The HCS-210 is a wall mounting touch screen control panel that controls up to 255 motorized winches including a number of variable speed motorized winches. The LCD touch screen allows any user to familiarize to it quickly. It also uses Motion-Status Arithmetic Engine (MSAE) to intelligently provide precise controlled response times. The flexible grouping control caters to the need for automatic movement and group assignment, label, or edit. The multi-level login provides administrator and operator to have different access to the system which also prevents unauthorized use. The HCS-210 comes with a wall mount bracket for wall installation.

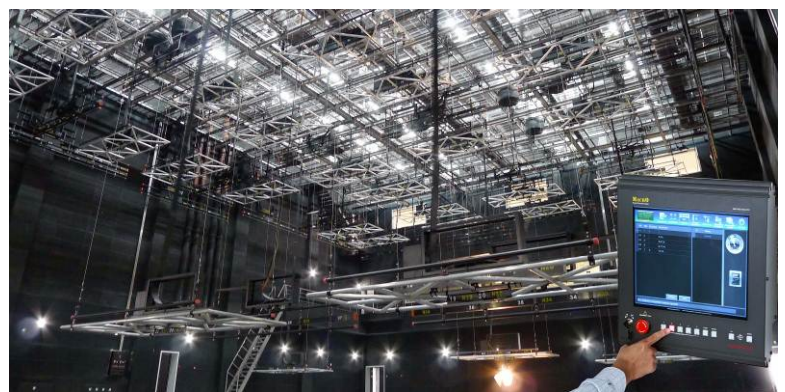

### Mechanical Data

Construction	Extruded aluminum top and bottom edges together with light weight rigid aluminum alloy sheets construction.
Paint / finish	Dark grey epoxy-polyester powder paint
Wall mounting	Wall mount bracket at the back of panel, supplied

### Electrical Data

Power input	200V~240VAC; ON/OFF switch and START press button
Frequency	50 ~ 60 Hz
Motors	Max. 255 motors per system
Ethernet port	RJ45 socket
Emergency-stop	Local: front panel; remote: female XLR 3-pin socket
Cooling fan	Not required

### Product Features

Control motions	Up, down and emergency stop
Safety alarms	<ul style="list-style-type: none"> <li>* Position monitoring</li> <li>* Emergency stop</li> <li>* Over current</li> <li>* Over weight</li> <li>* Over travel limit</li> <li>* Logical upper/lower limits</li> <li>* Physical upper/lower limits</li> <li>* Slack wires</li> </ul>
System Control	<ol style="list-style-type: none"> <li>1) Administrator: <ul style="list-style-type: none"> <li>* Create &amp; edit hoist system design</li> <li>* Account management for Operator level</li> <li>* Preset hoist system status</li> </ul> </li> <li>2) Operator: <ul style="list-style-type: none"> <li>* Control the preset system</li> </ul> </li> </ol>
Hoist Control	<ol style="list-style-type: none"> <li>1) Individual</li> <li>2) Groups <ul style="list-style-type: none"> <li>* Group assign or edit</li> <li>* Group labeling</li> <li>* Automatic movement</li> </ul> </li> </ol>

### Display Data

Screen	17" 4:3 TFT resistive touchscreen
Resolution	1280 X 1024
Contrast	1000 : 1
Viewing angles	H 170° / V 160°

### Operational Data

Touch screen	Full functions operation
Keyboard	<ul style="list-style-type: none"> <li>5 GROUP buttons for grouping shortcut with back light;</li> <li>CLEAR button with back light;</li> <li>ENTER button with back light;</li> <li>UP and DOWN buttons for hoist movement control with back light;</li> <li>ON/OFF key for keyboard lock;</li> <li>E-stop button for emergency power cut off to all motors connected to the system.</li> </ul>
Network	Ethernet connection available
System security	Two levels password access to the system: <ol style="list-style-type: none"> <li>1) administrator</li> <li>2) operator</li> </ol>

### Installation Data

Mounting method	Fix to structural wall by 4 x M10 bolt at any orientation
Power connection	Connect to a 220VAC wall socket with IEC power cord

### Environmental Data

Operation humidity	5-95% non-condensing
Operation temperature	0-40°C (32-104°F)
Installation place	indoor

### Standards

CE LVD directives and standards complied	
CE EMC directives and standards complied	

### Physical Data

Model	HCS 210 / 210C
Weight	5kg
Size (mm)	W / H / D 435 * 474 * 154

### Ordering Information

Model No.	Ordering number
HC -100	E3A0
HCS-210	
HCS-210C	
HCS-PC	
MC-TMC-1	E410
MC-PSC-2	W450

HCS ~C= Console Server version

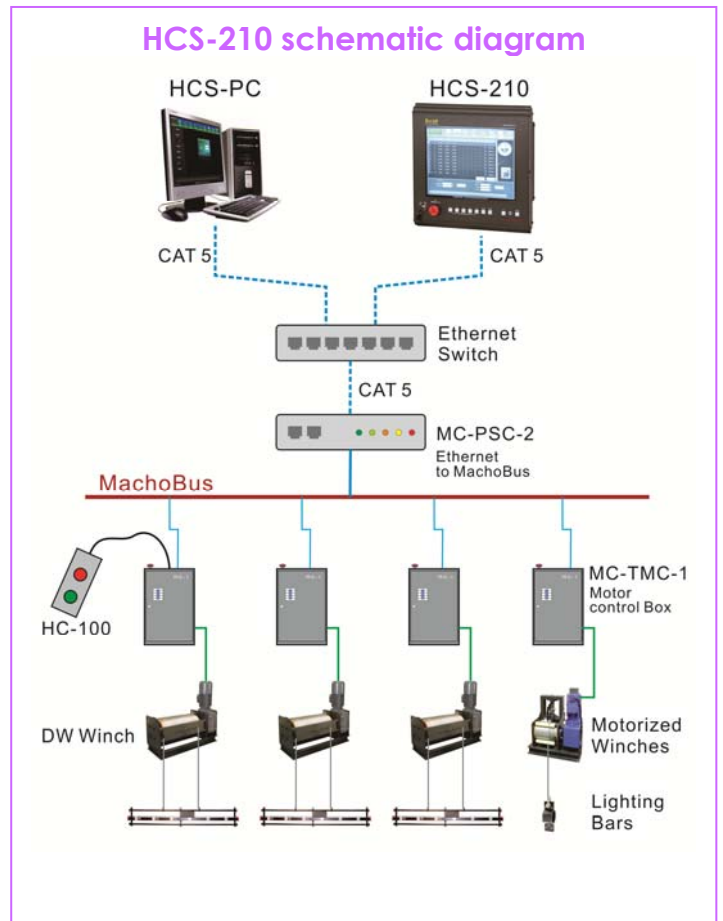
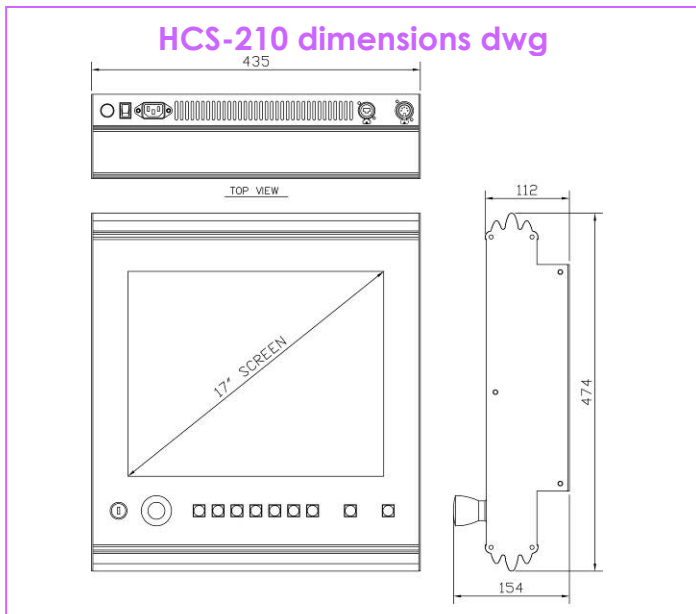

ISO 9001:2000  
ISO 14001:2004

Macostar reserves the right to change the specification without prior notice.  
Macostar International Ltd: Macho-HCS210 - V1.4 - 03 Jan 2013